

APX05SXX00WP-200

5W Open Frame Switch Mode Power Module

APX05SXX00WP-200 series is the ZETTLER highly efficient green power AC/DC or DC/DC Converter series. They feature wide input range accepting either AC or DC voltage, high reliability, low power consumption and reinforced isolation. All models are particularly suitable for industrial control, electric power, instrumentation and smart home applications which have high requirement for dimension. For extremely harsh EMC environment, we recommend using the application circuit show in Application Design Reference of this datasheet.

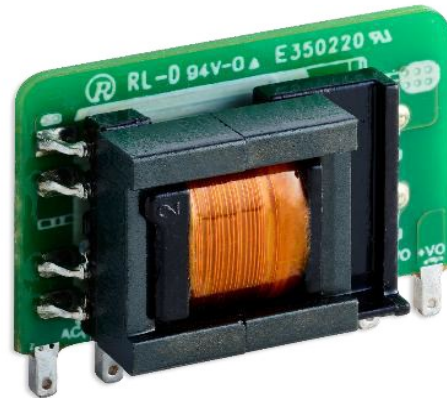

KEY FEATURES

- PCB mounted switching power supply
- AC input voltage range: 85Vac ~ 305Vac
- DC input voltage range: 70Vdc ~ 430Vdc
- Ambient temperature range: -40°C ~ 85°C
- Isolation voltage: Input – Output \geq 3600Vac / 60S
- EN61000-4-4 \pm 4KV (refer to page 2 - Safety and EMC compliance)
- Safety compliance with: EN IEC 61558-1:2019, EN IEC61558-2-16:2009+A1, EN IEC 62368-1:2020+A11

YOUR BENEFITS

- Compact size, easy installation
- High efficiency / Low standby power consumption < 0.15W max @ 230Vac
- Built-in over current, over voltage protection, short current protection
- Silicon free, phosphorus free

SELECTION GUIDE / MODEL LIST

Part No.	Output power (W)	DC voltage (Vdc)	Rated output current (max)	Efficiency @ 230Vac input Typ.	Ripple & Noise (max)
APX05S0300WP-200	3.3W	3.3Vdc	1000mA	69%	150mVpp
APX05S0500WP-200	5W	5Vdc	1000mA	76%	150mVpp
APX05S0900WP-200	5W	9Vdc	560mA	77%	150mVpp
APX05S1200WP-200	5W	12Vdc	420mA	79%	150mVpp
APX05S1500WP-200	5W	15Vdc	340mA	79%	150mVpp
APX05S2400WP-200	5W	24Vdc	210mA	81%	150mVpp

ZETTLER

APX05SXX00WP-200

TECHNICAL DATA

INPUT CIRCUIT

AC Rated Input Voltage	100 ~ 277 Vac	
DC Rated Input Voltage	120 Vdc ~ 390 Vdc	
Voltage Range	85 ... 305Vac or 70 ... 430Vdc	
Frequency (Hz)	47 ... 63 Hz	
Current (Full load)	115Vac	230Vac
	200mA	100mA
Inrush Current (<500us)	20A	40A
No Load Loss	0.15W@230Vac	
HOT PLUG	Not applicable	

OUTPUT CIRCUIT

Voltage (V)	Refer to "Model List" on page 1
Current (mA) max.	Refer to "Model List" on page 1
Voltage Accuracy	±5%@(10%-100% load)
Line Regulation	±1.5%(at rated load)
Load Regulation	±3%@(10%-100% load)
Minimum Load (mA)	10 mA
Ripple & Noise (mV)	Refer to "Model List" on page 1
Efficiency (typ.)	Refer to "Model List" on page1
Start-up Time	3s

GENERAL DATA

Dielectric Strength IP/OP	3600 Vac; at see level for 1 min.
Insulation Resistance	I/P - O/P 500Vdc≥100MΩ @ 25°C temperature, @70RH humidity
Leakage Current	< 0,20 mA @ input voltage 305 Vac
Over Current Protection	Hiccup mode, self recovery
Short Circuit Protection	Hiccup mode, self recovery
Standby Power	< 0.15W
Flammability	UL-94V0
Soldering	265+/-5°C ;10sec.max.
Pin Material	Tinned copper alloy for THT PCB mounting
Size / Weight	27,21x19.6x11 [mm] 4.8g(ref.)
Operating Temperature	-40°C...+ 85°C (Reference to the De-rating Curve) @free air convection
Operating Humidity	10-90% RH
Storage Temperature	-40°C...+105°C
Storage Humidity	5...95% RH
Temperature Coefficient	±0.15%/°C (0~60°C)
Resistance to Solder Heat	260±5°C,5-10Sec

SAFETY & EMC COMPLIANCE

Safety Standards	Compliance with EN/IEC/UL62368-1;IEC/EN60335-1;IEC/EN61558-2-16	
Conformity	RoHS	
Agency approvals	TÜV Rheinland: R 50671633	EN IEC 61558-1:2019 ; EN 61558-2-16:2009+A1; EN62368-1:2014 + A11
	UL: 309909	EN IEC 62368-1:2020, EN IEC 62368-1:2020/A11:2020
EMI /EMC	CISPR32/EN55032 CLASS A (Recommended circuit 1, 4)	
	CISPR32/EN55032 CLASS B (Recommended circuit 2, 3)	
ESD	IEC/EN 61000-4-2 Contact ±6KV perf. Criteria B	
radiated immunity	IEC/EN61000-4-3 10V/m perf. Criteria A	
EFT/burst	IEC/EN61000-4-4 ±2KV (Recommended circuit 1, 2) perf. Criteria B	
	IEC/EN61000-4-4 ±4KV (Recommended circuit 3, 4) perf. Criteria B	
Surge	IEC/EN61000-4-5 line to line ±1KV (Recommended circuit 1, 2) perf. Criteria B	
	IEC/EN61000-4-5 line to line±2KV (Recommended circuit 3, 4) perf. Criteria B	
Conducted immunity	IEC/EN61000-4-6 10Vr.m.s perf. Criteria A	

Need to add external EMC component (Reference to the Schematic)

APX05SXX00WP-200

MECHANICAL DESIGN SPECIFICATION

Mechanical dimensions view

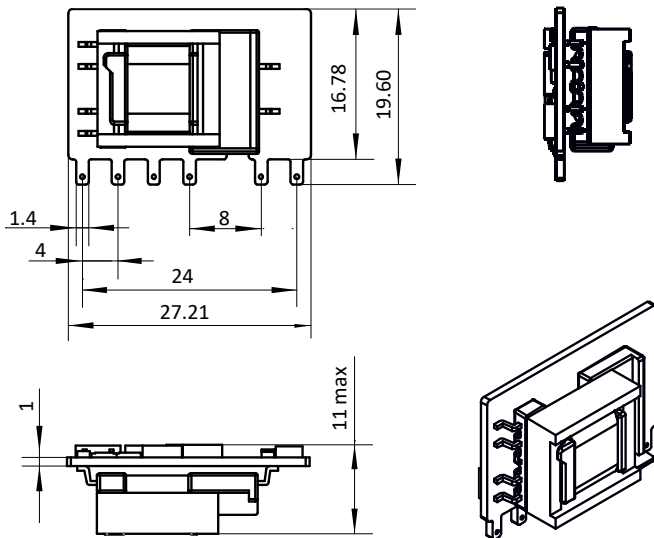

NOTE:

1.) Unit: [mm]

2.) Tolerance: ± 1 mm

Recommended PCB layout

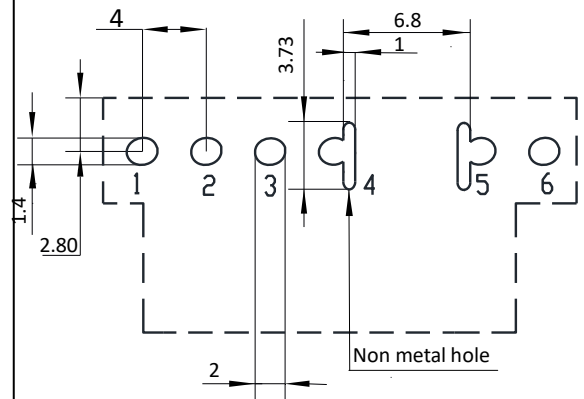

Pin assignment

Pin	Function
1	AC (L)
2	AC (N)
3	+V(cap)
4	-V(cap)
5	-Vo
6	+Vo

TYPICAL CHARACTERISTIC CURVE

Power derating curve (load vs temp)

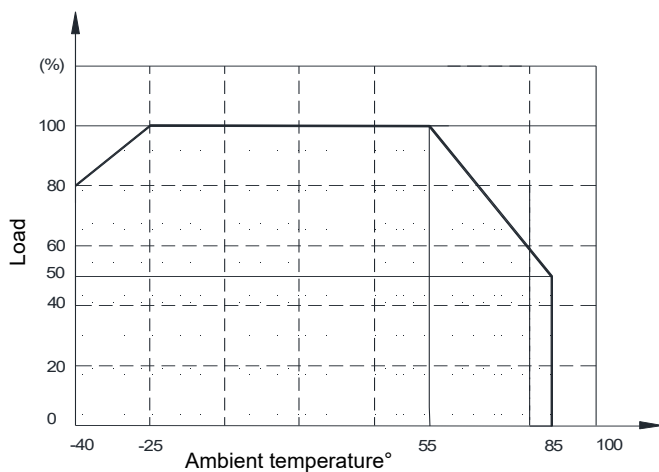

Power derating curve
(load vs input voltage @25°C)

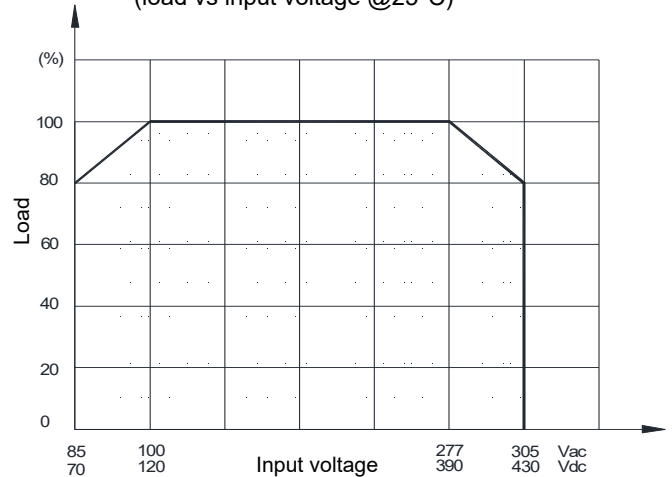

APX05SXX00WP-200

APPLICATION DESIGN REFERENCES

TYPICAL APPLICATION SCHEMATIC

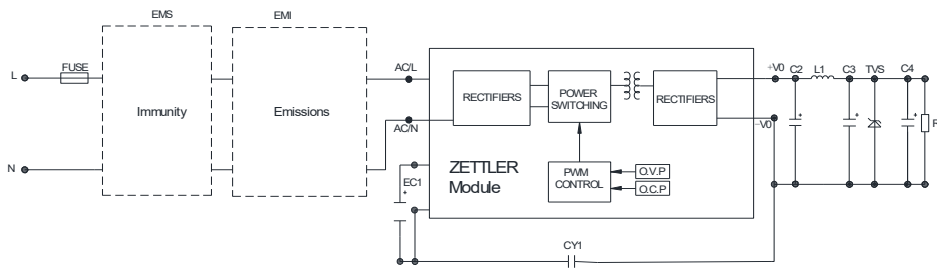

Reference table for selection of peripheral devices (EMC & Immunity devices not included)

Part no.	EC1 ¹	C2 (required)	L1 (required)	C3 ² (required)	C4	CY1 (required)	TVS ³
APX05S0300WP-200	22µF/450V (-40°C to 85°C with 85-305 Vac input)	820µ/6.3V (solid-state capacitor)	4.7µH max 60mΩ/ 2A	100µF/ 16V	0.1µF/ 50V (ceramic capacitor)	1.0nF/ 400Vac	SMBJ5.0A
APX05S0500WP-200		470uF/16V (solid-state capacitor)					SMBJ7.0A
APX05S0900WP-200	10µF/450V (-25°C to 85°C with 85-305 Vac input or 40°C to 85°C with 165-305 Vac input)	270uF/16V (solid-state capacitor)		47µF/ 35V			SMBJ12A
APX05S1200WP-200		220uF/35V					SMBJ20A
APX05S1500WP-200							SMBJ20A
APX05S2400WP-200							SMBJ30A

- Note:
- 1) Recommended to use a capacitor with ripple current >200 mA at 100 kHz.
 - 2) Recommended to use a high frequency, low ESR, electrolytic capacitor (<= 1.1Ω at -40 C) with at least 20% margin on voltage rating.
 - 3) A suppressor diode (TVS) is recommended to protect the downstream application in case of converter failure and should be rated for a minimum of 1.2 times the converter's output voltage.
 - 4) The FUSE component is required, recommended to use a slow break fuse with 1A/300V SPEC.

Reference table for environment and EMC selection

Recommended circuit	Application environment	Typical industry	Input voltage range	Environment temperature	Emissions	Immunity
1	Basic application	None	85~305Vac	-40°C to 85°C	Class A	Class III
2	Indoor civil	Smart home/Home appliances (2 Y-caps)				
	Indoor general	Intelligent building/ Intelligent agriculture				
3	Indoor industrial	Manufacturing workshop		-25°C to 55°C	Class B	Class IV
4	Outdoor general	ITS/Video monitoring/ Charging point/ Communication/Security and protection	-40°C to 85°C	Class A	Class IV	

Immunity design circuit reference

Emission design circuit reference

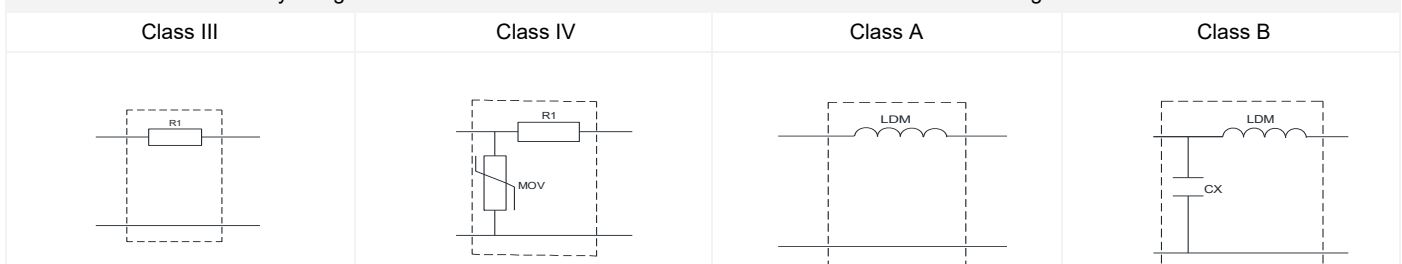

APX05SXX00WP-200

CIRCUIT 1 / DESIGN REFERENCE FOR BASIC APPLICATION

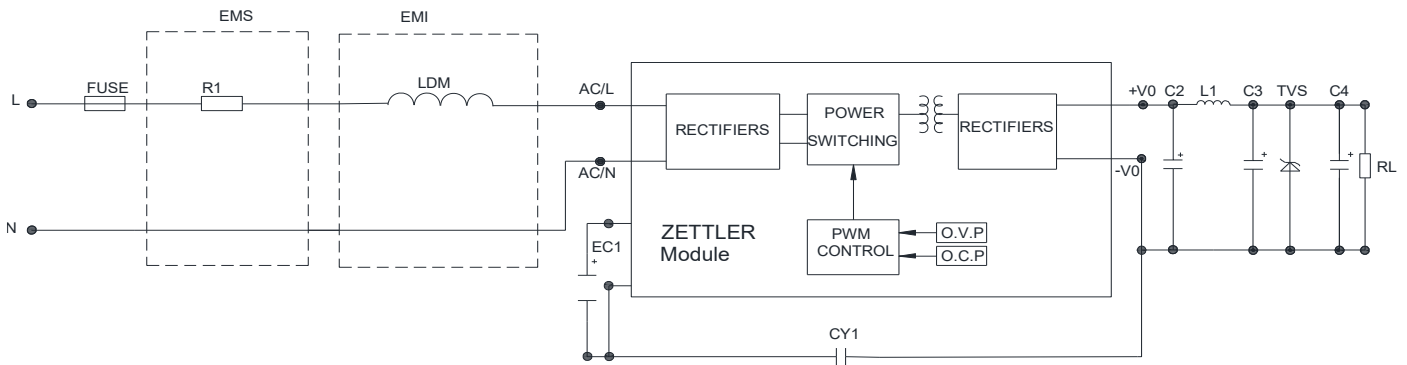

Application environmental	Ambient temperature range	Immunity Class	Emissions Class
Basic application	-40°C ~ 85°C	Class III	Class A

Component	Recommended value
FUSE (required)	1A/300V, slow blow
R1 (wire-wound resistor, required)	12Ω/3W
LDM	4.7mH/15Ω max/0.2A min

Note: R1 must be a wire-wound resistor; do not use a chip or carbon film resistor.

CIRCUIT 2 / DESIGN REFERENCE FOR INDOOR CIVIL AND GENERAL ENVIRONMENT

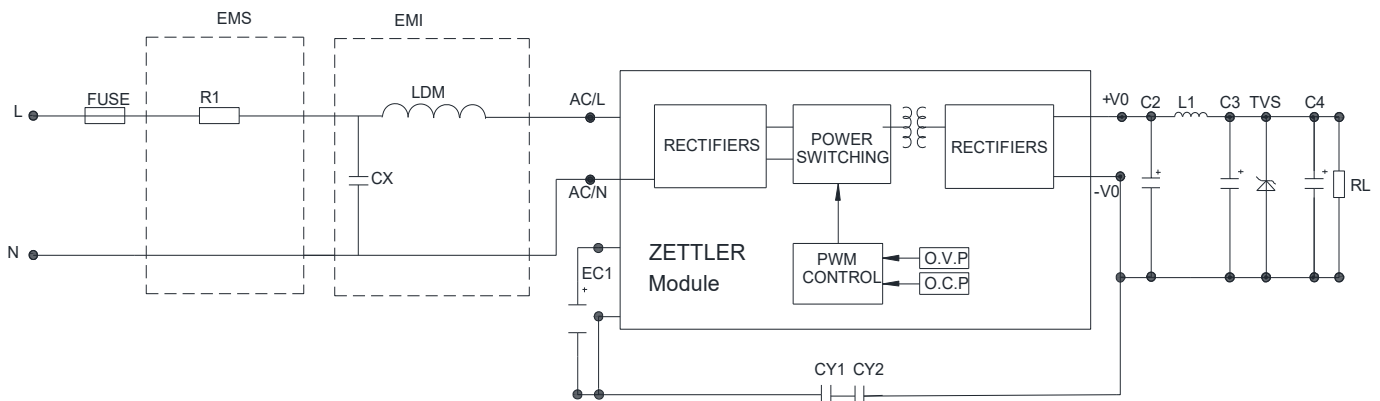

Application environmental	Ambient temperature range	Immunity Class	Emissions Class
Indoor civil / general	-25°C ~ 55°C	Class III	Class B

Component	Recommended value
FUSE (required)	1A/300V, slow blow
R1 (wire-wound resistor, required)	12Ω/3W
LDM	1.2mH/ 4Ω/0.2A
CX	0.1μF/310Vac

Note: R1 must be a wire-wound resistor; do not use a chip or carbon film resistor.

APX05SXX00WP-200

CIRCUIT 3 / DESIGN REFERENCE FOR INDOOR INDUSTRIAL ENVIRONMENT

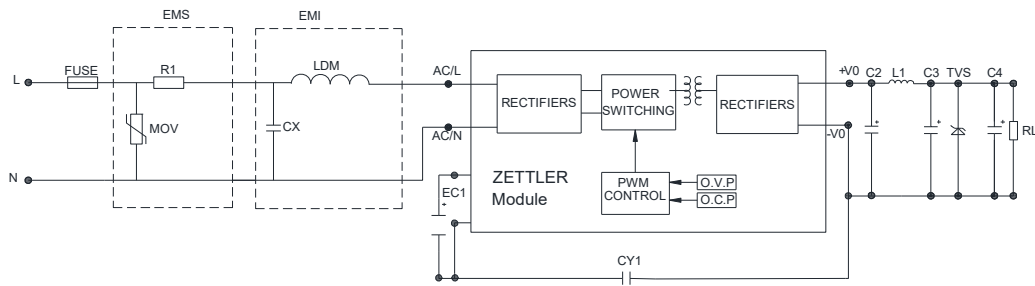

Application environmental	Ambient temperature range	Immunity Class	Emissions Class
Indoor industrial	-25°C ~ 55°C	Class IV	Class B

Component	Recommended value
FUSE (required)	2A/300V, slow-blow
R1 (wire-wound resistor, required)	12Ω/3W
LDM	1.2mH/ 4Ω/0.2A
CX	0.1μF/310Vac
MOV	S14K350

Note:

- Many safety standards require a bleeder resistor no greater than 3.8MΩ in parallel with the X-capacitor.
- R1 must be a wire-wound resistor; do not use a chip or carbon film resistor.

CIRCUIT 4 / DESIGN REFERENCE FOR OUTDOOR GENERAL ENVIRONMENT

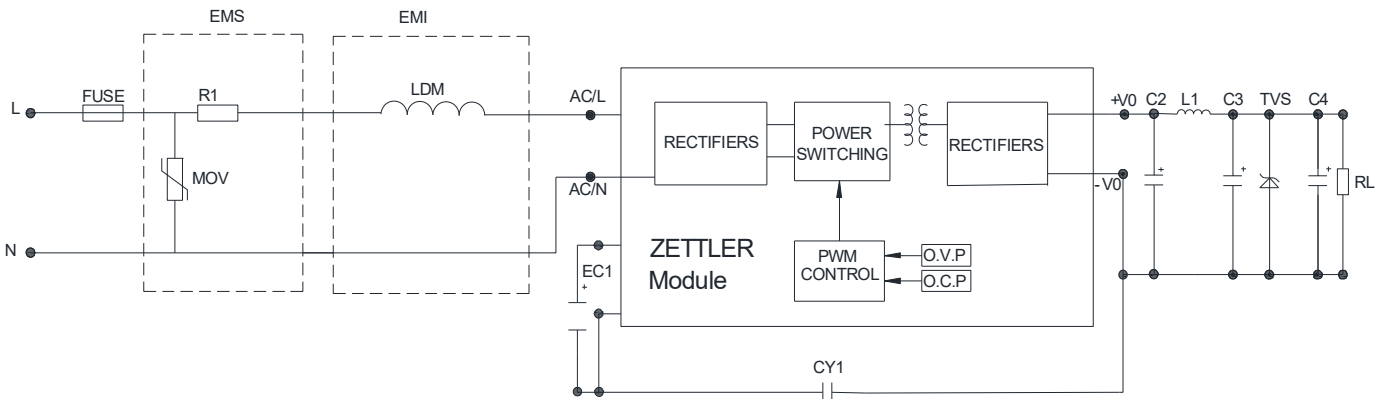

Application environmental	Ambient temperature range	Immunity Class	Emissions Class
Outdoor general environment	-40°C ~ 85°C	Class IV	Class A

Component	Recommended value
FUSE (required)	2A/300V, slow-blow
R1 (wire-wound resistor, required)	12Ω/2W
LDM	4.7mH/ 15Ω/0.2A
MOV	S14K350

Note: R1 must be a wire-wound resistor; do not use a chip or carbon film resistor.

NOTES

1. All values in this datasheet are at reference temperature of 23°C (73°F) unless stated otherwise.
2. The datasheet and the component's specifications are subject to change without notice.
3. Our products shall be classified according to ISO14001 and related environmental laws and regulations, and shall be handled by qualified units.
4. During operation, storage and transport, ambient temperature should be within the specified operating temperature range. Humidity should be in the range of 5% to 85% RH. Icing and condensation must be avoided.
5. For customized solution please contact our technical department.
6. Products are related to laws and regulations: see "Safety and EMC compliances".
7. Input voltages cannot exceed the specified voltage, otherwise permanent or irreparable damage may be caused.
8. Evaluate the component's performance and operating conditions under the worst-case conditions of the actual application.
9. This is open frame module and therefore protection against harmful ingress of dust, solid objects and moisture should be provided from the customer.
10. This is open frame module and customer shall provide adequate protection against contact hazardous live parts and shall have no risk of an electric shock from stored charge on capacitors.
11. By installing external components customer should provide sufficient distance to meet safety requirements (creepage distances).
12. Application examples provided herein are for reference purposes only and reflect Zettler's recommendations. It is the customer's responsibility to verify the component's performance within their specific application or to select alternative components that meet their system requirements

APX05SXX00WP-200

DISCLAIMER

This product specification is to be used in conjunction with the application notes which can be downloaded from the regional ZETTLER magnetics websites or in this document. The specification provides an overview of the most significant part features. Any individual applications and operating conditions are not taken into consideration. It is recommended to test the product under application conditions. Responsibility for the application remains with the customer. Proper operation and service life cannot be guaranteed if the part is operated outside the specified limits.

ZETTLER GROUP

Building on a foundation of more than a century of expertise in German precision engineering, ZETTLER Group is a world-class enterprise, engaged in the design, manufacturing, sales and distribution of electronic components. Our industry leadership is based on a unique combination of engineering competence and global scale.

For more information on other ZETTLER Group companies, please visit zettler-group.com. For support on this product or other ZETTLER relays, please visit one of the group sites below.

SITES FOR ZETTLER RELAYS

NORTH AMERICA

American Zettler, Inc.
www.azettler.com
sales@azettler.com

EUROPE

Zettler Electronics, GmbH
www.zettlerelectronics.com
office@zettlerelectronics.com

Zettler Electronics, Poland
www.zettlerelectronics.pl
office@zettlerelectronics.pl

CHINA

Zettler Group, China
www.zettlercn.com
relay@zettlercn.com

ASIA PACIFIC

Zettler Electronics (HK) Ltd.
www.zettlerhk.com
sales@zettlerhk.com



ZETTLER